

REARLOAD CONTAINERS



Manufactured by STI, Inc.

STANDARD FEATURES INCLUDED

- 14 Gauge Body
- Formed & Interlocking 12 Gauge Banding
- Plastic/Metal Lids
- Full Length Wrap-Around 7 Gauge Bumpers
- 1 1/2" Drain w/Plug
- 6" Mold-On Rubber Casters/10 Gauge Caster Plates
- All Seams Lap Formed
- Finished in *your* color

CONTAINER OPTIONS

- LIDS - Metal/Apartment/Recycling
- LID LOCKS - Manual/Automatic
- CASTERS - Polyurethane/Steel/Pneumatic/Skids
- CHANNELS - Dual Load/Conversions
- RECYCLING - Dividers/Baffles
- ID WELD -Serial#'s/Names/Capacities



Manufactured by STI, Inc.



SINCE 1976

*Custom Rolling, Bending & Forming - Machining - Industrial Coatings
Skids & Modules - Piping - Metal Fabrication - Field Erection - Engineering
Refuse Container Fabrication & Repair - Millwrights*

2141 East Anderson Street, Stockton, CA 95205
PO Box 6097, Stockton, CA 95206

209-948-9701

www.stocktontri.com
209-948-2310 Fax

Proud member of California Refuse & Recycling Council (CRRC), Solid Waste Association of North America (SWANA), Clara Mateo Garbage Association

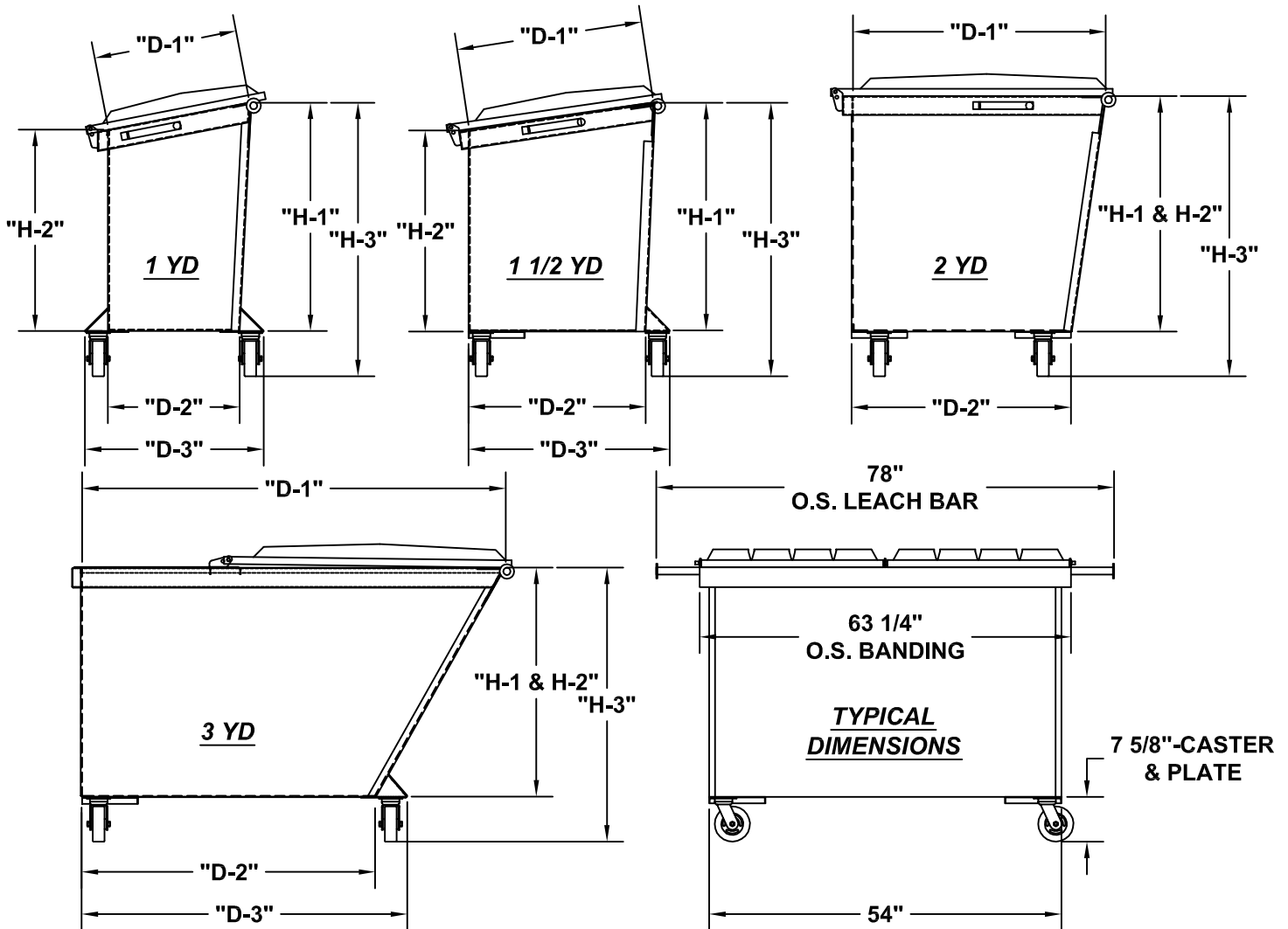

DESCRIPTION	FRONT HT. "H-1"	BACK HT. "H-2"	LOAD HT. "H-3"	TOP "D-1"	BOTTOM "D-2"	O/R WIDTH "D-3"	OUT-RIGGERS	
RL1	39 1/4"	34"	47"	29 1/2"	21 3/4"	30 1/2"	F/B	
RL1.5	39 1/4"	34"	47"	33 1/4"	30"	34 1/4"	F	
RL2	40"	40"	48"	43"	37"	N/A	NONE	
RL3	39"	39"	46 3/4"	72"	49 3/4"	56"	F	

These containers meet or exceed ANSI Z245.3 container safety requirements, and carry a 1 Yr. Warranty. Note: All specifications are subject to change without notice. Unless stated otherwise in writing, container sizes indicated are nominal sizes. Actual volume may vary from nominal sizes.